

2014

# **SURF SHOP**

CONCEPT STYLE GUIDE

OPTO wall header graphics - 22"w x 8"h



panel 1

panel 2

panel 3

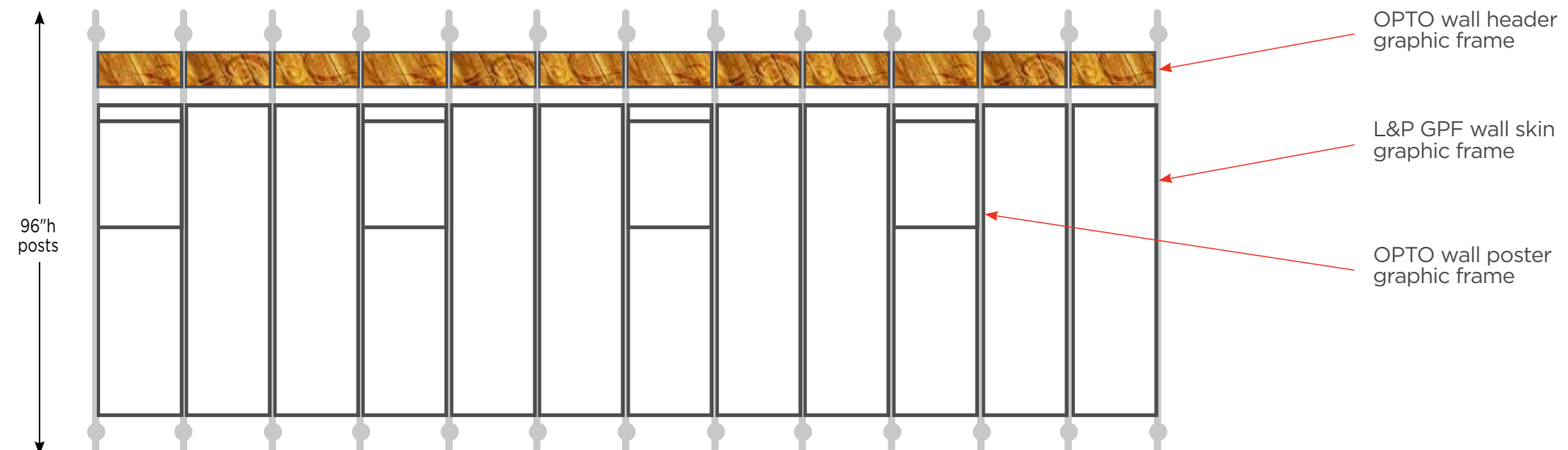

OPTO wall poster graphics - 22" w x 28" h



Version 1  
Blue/Gray with Wave  
white vendor logo

Version 2  
Blue/Gray  
white vendor logo

Version 1  
Blue/Gray with Wave  
white generic surf

Version 2  
Blue/Gray  
white generic surf

Version 1  
Blue/Gray with Wave  
white gender callout

Version 2  
Blue/Gray  
white gender callout

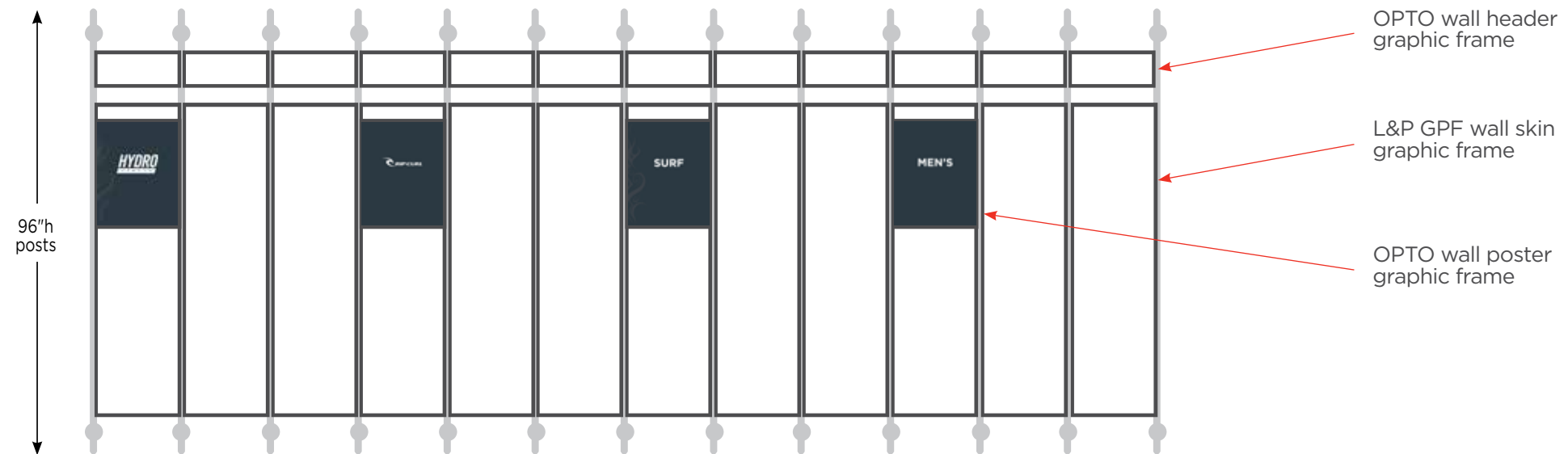

OPTO wall skin graphics - 21.375"w x 78.125"h

Elemental option



panel 1

panel 2

panel 3

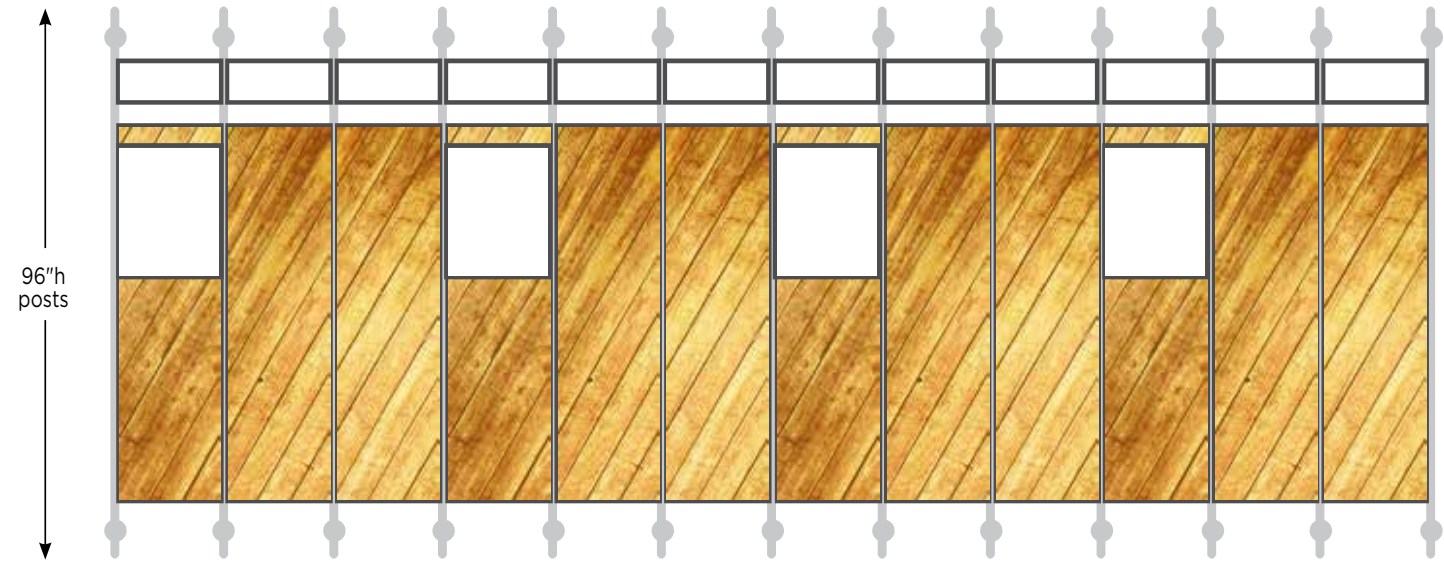

4-way banner graphics - 15"w x 29"h



Version 1  
Wood



Version 2  
Wood with Wave



Version 3  
Gray/Blue



Version 4  
Gray/Blue with Wave



OPTO G1 header graphics - 24" w x 8" h



Men's Version 1



Women's Version 1



Men's Version 2



Women's Version 2

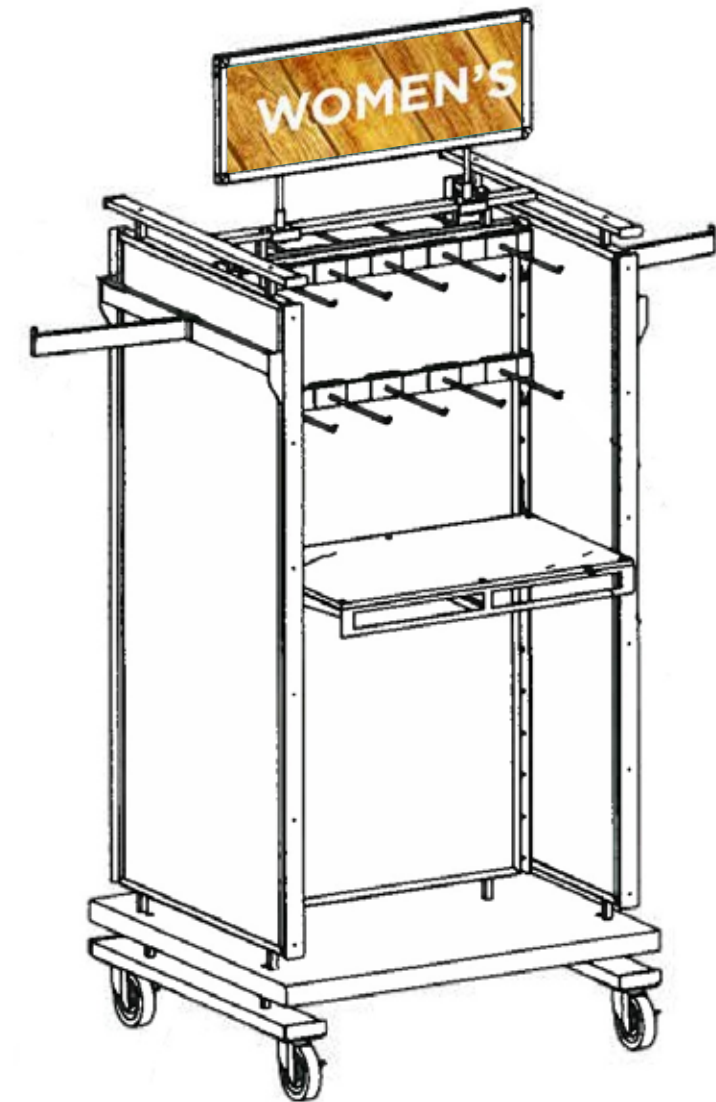

OPTO G2 header graphics - 48" w x 8" h



Men's Version 1



Women's Version 1



Men's Version 2



Women's Version 2

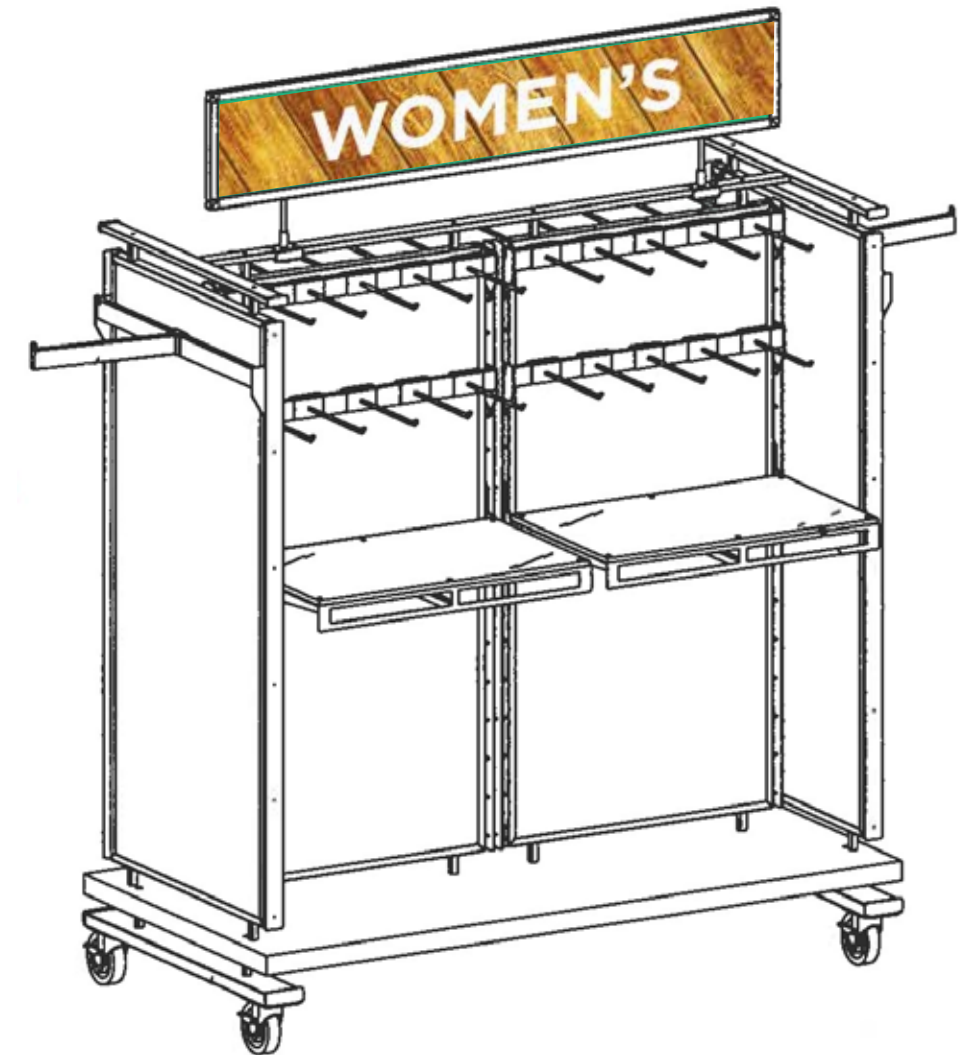

Surf department overview



# SURF SHOPS



# SURF SHOPS



# SURF SHOPS



# SURF SHOPS



# SURF SHOPS

